

Design of Bolted Connections: A Comparison of a Proposal and Various Existing Standards *

Pierre Quenneville

Professor of Timber Design, University of Auckland, Auckland, New Zealand

Abstract

The design of bolted connection in most international design standards is based on the computation of the resistance of assumed ductile failure modes further modified for the potential occurrence of brittle failure ones. Lately, various design proposals have been presented to cover the ductile and failure modes separately. A proposal for inclusion into the Canadian wood design standard is presented and its predictions of resistance for connection configurations that have been tested are compared to predictions using the current Canadian and European design standard for connections.

1. Introduction

There is an agreement in principle within the international timber engineering community that design standard sections dealing with timber bolted connections should be based on recognised mechanics models and that models must identify each potential mode of failure. Failure modes to be considered are the ductile ‘bearing failures’ and the brittle ‘fracturing failures’ in wood or other components of a connection. The mode with the lowest estimated capacity will be the governing one. Each mode may encompass a range of mechanisms. For example, the ductile modes will encompass the mechanisms associated with ‘Johansen type’ dowel connection yield models, the so-called European Yield Model (EYM). The brittle modes will include mechanisms like ‘tear out’ of a fastener group and ‘row shear failure’ in lines of fasteners.

As it is the case, in most design standards [1, 2] the approach for the design of multiple-bolted connections is solely based on the EYM, further modified in certain cases to attempt to account for potential brittle failure modes. As a result of the many recent studies on the brittle behaviour of connections in timber structures [3, 4, 5] failure modes have been identified and are as shown in Figure 1.

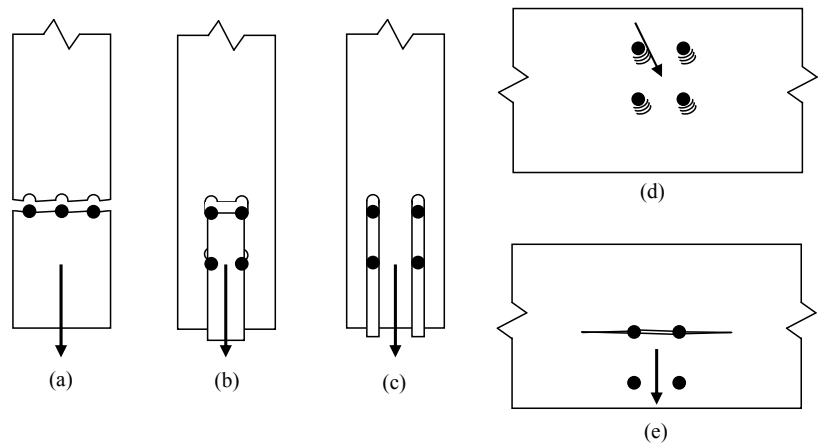

Figure 1. Observed failure modes for timber bolted connections (a) net tension (b) group tear-out (c) row shear (d) bearing (e) splitting

2. Proposed Design Approach

2.1 Connection Resistance

In the proposed Canadian design approach, capacity of dowel fastener connections will be the minimum value determined from a series of possible failure scenarios. Not all failure modes are possible in wood members loaded either parallel or perpendicular-to-grain and corresponding capacities will be compared to either the load applied or a function of its component parallel or perpendicular-to-grain. The designer will need to verify the following three cases:

$$N_f \leq R_{r_b} \quad (1)$$

$$N_f \cos(\theta) \leq \text{Minimum} (R_{r_{rs}}, R_{r_{gt}}, R_{r_{nt}}) \quad (2)$$

$$N_f \sin(\theta) \leq R_{r_{sp}} \quad (3)$$

where N_f = design action effect, R_{r_b} = bearing design capacity, $R_{r_{rs}}$ = row shear design capacity, $R_{r_{gt}}$ = group tear-out design capacity, $R_{r_{nt}}$ = net tension design capacity and $R_{r_{sp}}$ = splitting design capacity. This format is based on the assumption that the brittle failure modes are uncoupled which has been verified for brittle failure modes in splitting ring connections [6].

* Presented at World Conference on Timber Engineering (WCTE) 2008, Japan.

2.2 Bearing Capacity Equation

For dowel type fasteners failing in one of the ductile modes, as shown in Figure 1(d), the bearing design capacity is given by:

$$R_{rb} = \phi B_u n_s n \gamma k_1 k_2 \quad (4)$$

where:

- ϕ = strength reduction factor
- B_u = minimum lateral ultimate bearing capacity (from the EYM equations)
- n = total number of fasteners in the joint
- n_s = number of shear planes
- k_1 = duration of load factor for strength
- k_2 = service condition factor
- γ = factor to convert average value to 5th percentile resistances

where the lateral ultimate bearing capacity, per shear plane is obtained from the well known EYM equations developed by Johansen [7] for one shear plane or for two shear planes, whichever is applicable.

For each wood member loaded at an angle θ , the embedment strength is obtained from:

$$f_{i\theta} = \frac{f_{i\text{par}} f_{i\text{perp}}}{f_{i\text{par}} \sin^2(\theta) + f_{i\text{perp}} \cos^2(\theta)} \quad (5)$$

where:

- $f_{i\theta}$ = embedment strength of member “i” for a fastener bearing at angle θ relative to grain (MPa).
- $f_{i\text{par}}$ = average embedment strength for fastener bearing parallel to grain ($\theta = 0^\circ$), (MPa)
= $88 G (1-0.01d)$ (value for a 15 min test duration)
- $f_{i\text{perp}}$ = average embedment strength for fastener bearing perpendicular to grain ($\theta = 90^\circ$), (MPa)
= $40 G (1-0.01d)$ (value for a 15 min test duration)
- G = mean relative density of the wood-based material, also known as specific gravity, for the oven dry condition. It is calculated as the density of the material for the oven dry condition normalized relative to the density of water, based on mass and volume after oven drying.
- θ = angle of bearing relative to the strong material axis (parallel to grain of member)

It should be noted that there are no modification factors for multi-fastener applications in equation 4. The use of the EYM equations is for the predictions of the design capacity for ductile failure modes only.

2.3 Row Shear Capacity Equation

The row shear design capacity of dowel fasteners in a member under tension load is given by (refer to Figure 1(c)):

$$R_{rs} = \phi RS_{i\text{min}} n_r \gamma k_1 k_2 \quad (6)$$

where:

- $RS_{i\text{min}}$ = minimum row shear capacity of any row in the connection
= minimum ($RS_1, RS_2, \dots, RS_{nr}$)
- RS_i = average shear capacity along two shear planes of fastener row “i”, in N
$$= \frac{2 (f_{v\text{avg}}) K_{ls} t n_{fi} a_{cr}}{3} = \frac{2 (16.6 \cdot G^{0.85}) K_{ls} t n_{fi} a_{cr}}{3} = 11.1 G^{0.85} K_{ls} t n_{fi} a_{cr}$$
- $a_{cr\ i}$ = minimum of e_t and s_b for row “i” (see Figure 2), mm as identified in [8]
- $f_{v\text{avg}}$ = member average shear strength, MPa, equal to $16.6 G^{0.85}$
- K_{ls} = factor for member loaded surfaces
= 0.65 for side member, 1 for internal member, as determined in [9]
- n_{fi} = number of fasteners in row “i”
- n_r = number of rows in the joint as per load component (see Figure 2)
- t = member thickness, mm

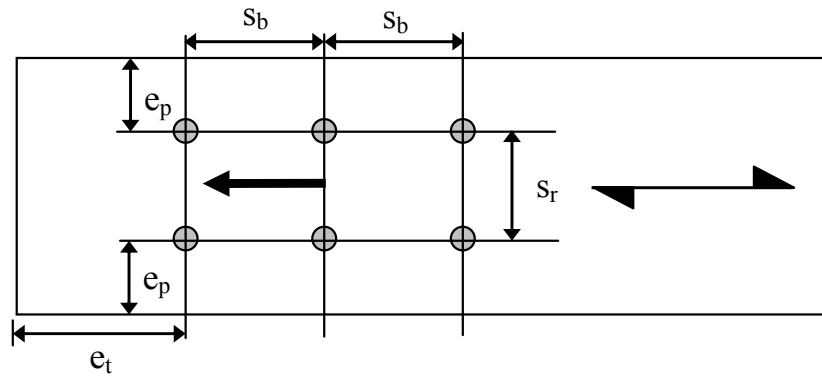

(Note: $n_r = 2$, $n_f = 3$)

Figure 2. Nomenclature of the connections configuration variables parallel-to-grain

2.4 Group Tear-out Capacity Equation

The group tear-out design capacity of dowel fasteners in a member under tension load is given by (refer to Figure 1(d)):

$$R_{r_{gt}} = \phi GT \gamma k_1 k_2 \quad (7)$$

where:

$$GT = \frac{(RS_1 + RS_{nr})}{2} + \frac{(f_{t_{avg}} \cdot A_{GT-net})}{3} = \frac{(RS_1 + RS_{nr})}{2} + \frac{(170.7 G^{1.01} \cdot A_{GT-net})}{3}$$

$$= \frac{(RS_1 + RS_{nr})}{2} + (56.9 G^{1.01} \cdot A_{GT-net})$$

RS_1 = shear capacity along row 1 bounding the fastener group, equal to $6.66 G^{0.85} K_{js} t n_{fl} a_{cr1}$

RS_{nr} = shear capacity along row “n_r” bounding the fastener group, equal to $6.66 G^{0.85} K_{js} t n_{fi} a_{crnr}$

$f_{t_{avg}}$ = member average tension strength, MPa, equal to $170.7 G^{1.01}$

A_{GT-net} = critical area between the two rows 1 and n_r, mm²

2.5 Net Tension Capacity Equation

The net tension design capacity of a member at a group of dowel fasteners is given by (refer to Figure 1(a)):

$$R_{r_{nr}} = \phi T_n \gamma k_1 k_2 \quad (8)$$

where:

ϕ = strength reduction factor

$T_n = f_{t_{avg}} A_n$

A_n = member net area, mm²

2.6 Splitting Capacity Equation

The splitting design capacity of a member loaded perpendicular-to-grain by dowel fasteners is given by (refer to Figure 1(e)):

$$R_{r_{sp}} = \phi S_p \gamma k_1 k_2 \quad (9)$$

where:

$$S_p = \frac{500 (n_r d t)^{0.8} \cdot K_{loc}}{A_b B_b C_b \cdot (n_{fi} d)^{0.2}} \text{ in N}$$

K_{loc} = factor taking into account the position of the connection

= 1 for interior connection, i.e. $e_t \geq \text{depth} - e_p$

= 0.5 for exterior connection, i.e. $e_t \leq \text{depth} - e_p$

$A_b = 0.85 - ((n_{fi}-1) \cdot 0.1) + ((n_r-1) \cdot 0.25)$

$B_b = 1.05 + s_b(0.017n_r - 0.019) - s_r(0.0034n_r - 0.0034) - 0.15n_r$

$C_b = 11.4e^{-3.08r}$

$r = (e_q + (n_{fi}-1)s_b) / \text{depth}$

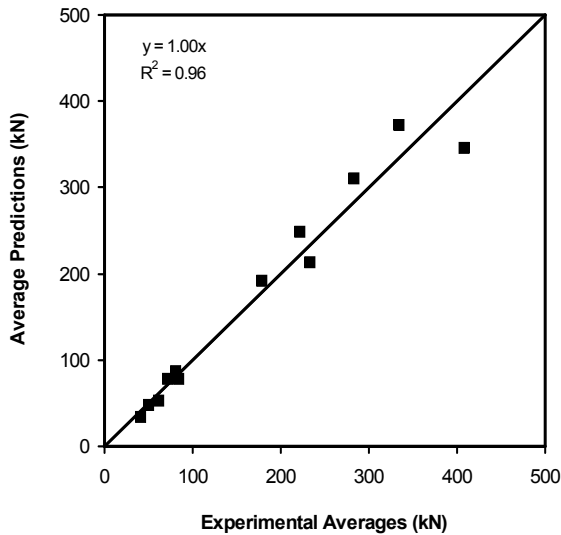

Figure 3. Predicted averages of connection capacity vs. experimental resistance averages in bearing failure mode

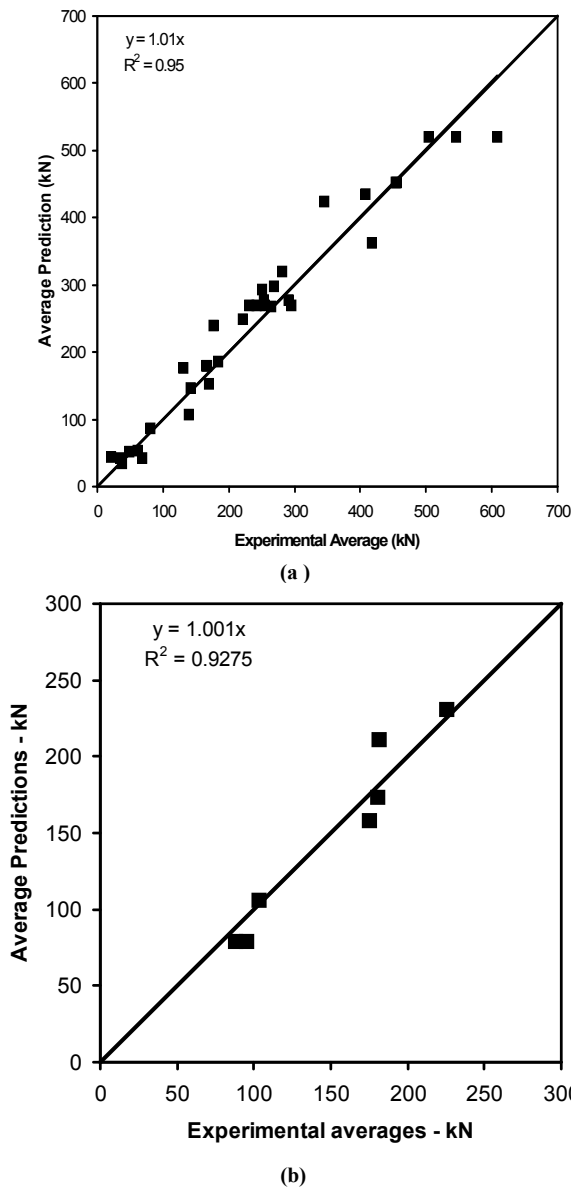

Figure 4. Predicted averages of connection capacity vs. experimental resistance average in row shear failure mode (a) steel-wood-steel connections (b) wood-steel-wood connections

3. Discussion

The effectiveness of the various equations in predicting the mode of failure and resistance of connections tested in various laboratory studies is best shown graphically. Figures 3 to 6 show graphs with the experimental average values and associated predictions of the average capacity of bolted connections. The experimental data is from over 150 various connection configurations that have been tested in either parallel or perpendicular-to-grain orientations. The experimental data is for a 15 minutes test duration and has not been modified. The predictions are for averages and thus, the factor to convert average to 5th % values (γ) has been omitted in the calculations. The experimental data was collected on D-fir and Spruce-Pine glulam and D-fir timber. Each point on the graphs represents the average of 10 specimens for a given configuration.

A comparison between the experimental results for timber bolted connections that failed in a purely ductile manner and the predictions of average capacity using equation 4 is shown in Figure 3. The accuracy of the predictions using the Johansen's approach, or the EYM is adequate.

The graphs in Figure 4 are for two groups of configurations that failed in the row shear mode. One is for connections in a steel-wood-steel and the other one is for wood-steel-wood configuration. The predictions for the connection capacity were obtained using equation 6. The accuracy of the predictions is more than adequate in this case as well. Another configuration, not shown graphically, is for the steel-wood configurations. Predictions using equation 6 are also very good.

The other type of failure observed was the group tear-out mode (Figure 5). Predictions of the capacity were calculated using equation 7. Most specimens failing in the group tear-out mode had rows of bolts spaced at 3d. However, this observation does not apply to all connections. The number of rows and number of bolts in a row can significantly affect the resistance. For example, a two rows, three bolts connection with 5d row spacing will likely fail in row shear. By increasing, the number of bolts in the rows to 6, the failure mode will be a group tear-out. It is interesting to note that the capacity of connections with two bolt rows closely spaced is less than the capacity of a connection with only one row.

The graph shown in Figure 6 is for bolted connections in members loaded perpendicular-to-grain. The variables that affect the resistance most significantly are the vertical position of the bolt group with relation to the depth of the member and the spacing of bolt rows, if applicable.

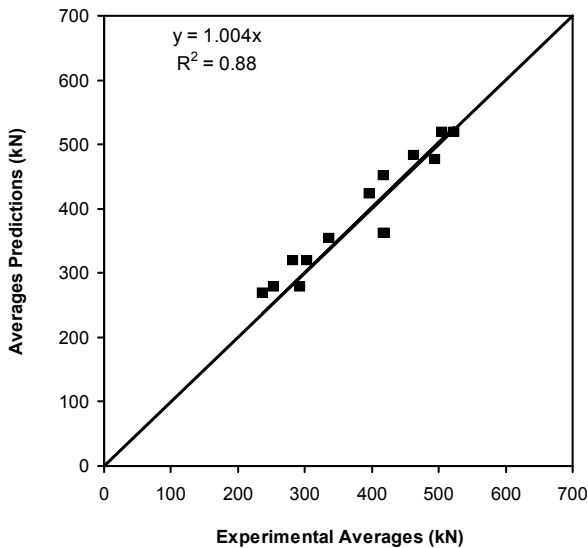

Figure 5. Predicted averages of connection capacity vs. experimental resistance averages in group tear-out failure mode

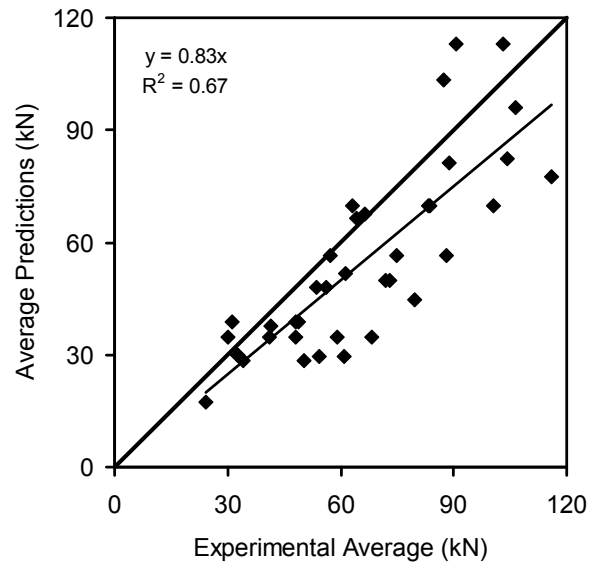

Figure 6. Predicted averages of connection capacity vs. experimental resistance averages bearing and splitting failures – connections loaded perpendicular-to-grain

However, the capacity of the connections will increase with an increase in row spacing, to reach the capacity of two – one row connections. Predictions of the capacity using equations 4 and 9 for the connections in members loaded perpendicular-to-grain are not as reliable. This is because equation 9 does not take into account the effect of all potential variables accurately. More research is being carried out on bolted connection loaded perpendicular-to-grain to better describe those variables.

A general set of conclusions can be drawn from all of the configurations tested and the capacities of connections measured. First, the highest resistance of fasteners is obtained when bearing failure controls the resistance, i.e. bearing failure of the wood or combination of bearing failure in wood and yielding of the bolts (the EYM failures). Second, the next highest capacity of fasteners is reached when the connection fails in row shear mode. One should note that there are no advantages in having dissimilar end distances and in-row bolt spacing as the lowest of the two variables values will govern the row shear failure. Designers should thus specify connections with equal bolt end distances and in-row bolt spacings. Third, the least efficient use of fasteners is observed when the connection fails in group tear-out mode.

To use equations 4, 6, 7, 8 and 9 for design purposes, a load duration factor should be inserted to bring the “15 minutes test duration” predictions values to the “standard term” ones. Applicable values of the load duration modification factor may be obtained for each national design standard.

4. Comparisons of Proposal, Eurocode 5 and CSA O86 Design Approaches

In current design standards, brittle modes of failure are accounted for with the application of modification factors to the ductile lateral resistance design equations. This method converts the number of bolts in-the-row (n_{fi}) to the effective number of fasteners (n_{ef}) to obtain the connection strength. The adjustments utilized by each international design standard are derived from numerical models and/or limited independent experimental data. This has resulted in a significant capacity prediction disagreement from one standard to another with respect to bolted timber connections.

The European Design Standard, Eurocode 5, developed from work done by Jorissen [10], determines the effective number of fasteners in bolted timber connections by the relationship in equation 10, where “n” refers to the number of bolts in-the-row, and “ a_1 ” refers to the in-row bolt spacing.

$$n_{ef} = \min \left\{ \begin{array}{l} n \\ n^{0.9} \sqrt[4]{\frac{a_1}{13d}} \end{array} \right. \quad (10)$$

The Canadian Design Standard CSA O86 accounts for brittle behaviour by applying a set of modification factors in the form of equation 13. The group factor J_G is a numerical interpretation of available experimental data that takes into account the number of bolts in-the-row. For this modification factor, “t” refers to the thickness of the thinnest timber member, “s” refers to the bolt spacing in-the-row, and “N” refers to the number of bolts in-the-row.

$$J_F = J_G J_L J_R \tag{11}$$

where:

$$J_G = 0.33 \left(\frac{t}{d}\right)^{0.5} \left(\frac{s}{d}\right)^{0.2} N^{-0.3} \leq 1.0$$

$$J_L = \begin{cases} 1.0 & \text{for } e = 10d \\ \text{linear interpolation for intermediate values} \\ 0.75 & \text{for } e = 7d \end{cases} \quad \text{and} \quad J_R = \begin{cases} 1.0 & \text{for 1 row} \\ 0.8 & \text{for 2 rows} \\ 0.6 & \text{for 3 rows} \end{cases}$$

Graphical comparisons of the effective number of bolts (n_{ef}) are made between the existing modification factors of international design codes and the one calculated with the proposed design approach. Two steel-wood-steel connection configurations are used to make the comparisons. These configurations are outlined in Table 1, along with their corresponding graphs of the effective number of fasteners for each group (Figure 7).

Table 1 – Characteristics of the connection configurations used to compare n_{ef} of the proposed design approach and n_{ef} of existing standards

Group	Glulam Species	t mm	b mm	d mm	n_r	e	s_b	s_r
a	Spruce-Pine	80	190	19.1	1	7d	4d	--
b	Spruce-Pine	130	266	19.1	2	7d	4d	3d

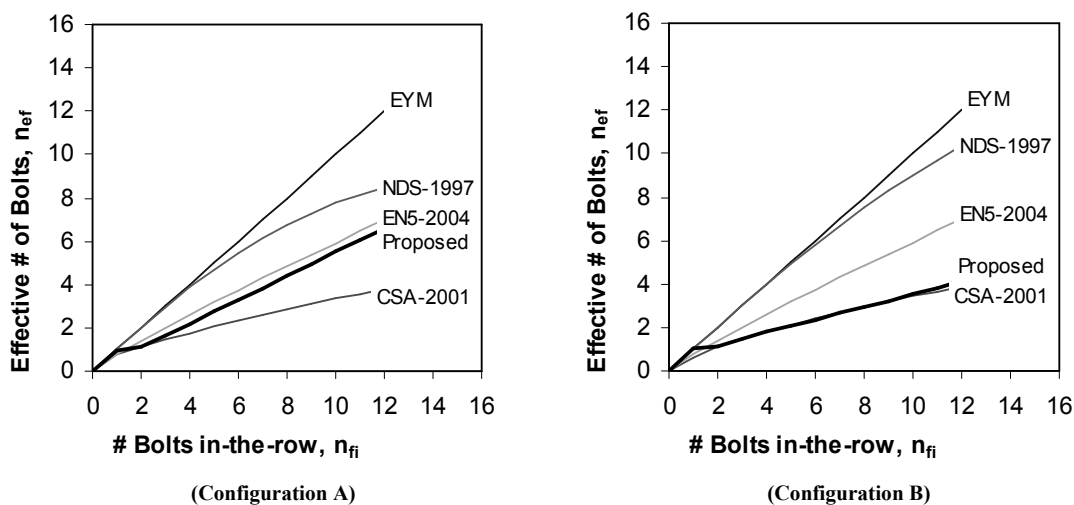

Figure 7. Comparison of the effective number of in-row bolts vs. the number of in-row bolts for various existing standards and the proposed design approach

Figure 7 shows the n_{ef} predictions for the EYM model (most efficient use of fasteners), the Eurocode 5, the Canadian CSA O86 and finally, for the proposed set of design equations. For the one-row configuration of Configuration A, the predictions of n_{ef} using the proposed design equations are similar to the n_{ef} obtained using the procedures in Eurocode 5 [2]. The predictions of n_{ef} obtained by the proposed approach are controlled by the row-shear design equation, which suggests that this mode of failure will occur for any number of bolts in-the-row.

The specifications of Configuration B are a replicate of the configurations tested by [8] for which the modification factors of the current Canadian design provisions [1] are based upon.

As seen in Figure 7 (Configuration B), the values of n_{ef} obtained using the proposed design approach are nearly identical to the n_{ef} obtained using CSA-O86 design equations. The n_{ef} relationship obtained using the proposed design approach

is governed by the equation for group tear-out failure mode. It is clear from comparisons of the capacity predictions for these two configurations that the proposed set of design equations is sufficiently comprehensive to adequately predict the resistance of connections currently covered by the Eurocode 5 and CSA O86 design standards. The equations for these two design standards were developed from two different sets of test data. The proposed design approach is thus capable of predicting adequately the resistance of three sets of experimental data.

5. Conclusion

A generalized design procedure that addresses all potential ductile and brittle modes of failure for bolted timber connections is presented. It is mechanics-based, and it offers the required framework to design most possible connection configurations with an adequate degree of precision. It proves to be comprehensive enough to replicate the particularities of the current Eurocode 5 and CSA O86 multi-fastener group factors (n_{ef} for Eurocode 5 and J_G for CSA O86). It is also sufficiently flexible to allow most cases to be designed with confidence, however, its applicability for other wood species and or engineered wood products should be verified experimentally.

6. References

- [1] Canadian Standard Association, *CSA O86-01 Engineering Design in Wood*, Mississauga, Canada, 2005.
- [2] EN 1995-1-1. 2004. Eurocode 5 – Design of timber structures. *CEN*, Brussels.
- [3] Quenneville, J.H.P., and Mohammad, M. On the failure modes and strength of steel-wood-steel bolted timber connections loaded parallel-to-grain. *Can Journal Civ Engr*, 27, pp. 761-773. 2000.
- [4] Leijten, A.J.M., and Jorissen, A. Splitting strength of beams loaded by connections perpendicular-to-grain, model comparison, *CIB-W18 meeting Proceedings*, paper 34-7-1, Venice, Italy. 2001.
- [5] Hanhijarvi, A., Kevarinmaki, A. and Yli-Koski, R. Block shear failure at dowelled steel-to-timber connections. *CIB-W18 meeting Proceedings*, paper 39-7-4, Florence, Italy. 2006.
- [6] Leijten, A.J.M., Kuiper, J. and Jorissen, A. Interaction between splitting and block shear failure of joints, *CIB-W18 meeting Proceedings*, paper 34-7-10, Venice, Italy. 2001.
- [7] Johansen, K.W. Theory of Timber Connectors. *Publications of the International Association of Bridge and Structural Engineering*. No. 9: 249-262. Bern, General Secretariat. 1949.
- [8] Bickerdike, M. 2006. Predicting the row shear failure mode and strength of bolted timber connections loaded parallel-to-grain. *M.A.Sc. Thesis, Department of Civil Engineering, Royal Military College of Canada*, Kingston, Canada. 231 p
- [9] Mohammad, M. and Quenneville, J.H.P. Behaviour of wood-steel-wood bolted glulam connections. *Can Journal Civ Engr*, 28, pp. 254-263. 2001.
- [10] Jorissen, A. Double Shear Timber Connections With Dowel Type Fasteners, *PhD thesis, Delft University Press*, The Netherlands, 264 p. 1998.
- [11] Massé, D., Salinas, J., and Turnbull, J. 1988. Lateral strength and stiffness of single and multiple bolts in glue-laminated timber loaded parallel to grain. *Engineering and Statistical Research Centre, Research Branch, Agriculture Canada*, Ottawa. 29 p.