

REFERENCES

Cooney, R.C. Collins, M.J.; 1979 "A wall bracing test and evaluation procedure". BRANZ Technical paper P21. (Rev. 1987).

King, A.B; Lim, K.Y.S: "Supplement to P21: An evaluation of P21 test results for use with NZS 3604:1990". BRANZ Report TR 90.

Lyngcoln, K.J: 1987: "Wood based panels - Properties required for their use in the tropics with special reference to low cost housing". Expert consultation on wood based panels, FAO, Rome

McLaughlan, J.M: "Properties of treated and untreated *Pinus radiata* plywood after 12 years' weathering". NZ Journal of Forestry Science 21(1):96-110 (1991)

PAA 1992 "Structural plywood bracing". Design manual, PAA, Brisbane.

Page; D.R: "Getting the best out of radiata pine weatherboards" NZ Journal of Timber Construction, 7(2) 1992

Reed, M,E; Walls R.J. 1992: "Construction Plywood Wall bracing system" Appraisal Certificate No 224 BRANZ

Standards Australia AS1604: Timber - Preservative treatment - sawn and round. SA Sydney

Standards New Zealand: NZMP3640 1992: Specification of the minimum requirements of the New Zealand Timber Preservation Council Inc. Standards NZ, Wellington

Standards New Zealand: NZS 3604 1990: Light timber frame buildings. Standards NZ, Wellington

FIRE RESISTANCE OF EPOXIED STEEL RODS IN GLULAM TIMBER

Andrew H. Buchanan

Associate Professor in Civil Engineering
University of Canterbury, Christchurch, New Zealand

and **David J. Barber**

Design Engineer

Connell Wagner, Wellington, New Zealand

SUMMARY

This research investigates the fire performance of epoxied rod connections in glue laminated timber. The epoxied rod connection has been assumed to have good fire resistance due to timber possessing low thermal conductivity. To investigate how full-size connections would react at elevated temperatures, computer modelling was used to analyse heat transfer through the charring wood and was validated by two series of tests. The first set of tests was to investigate the tension strength of the connection at elevated temperatures (40 to 90°C) by using an oven to heat the epoxied rod connection. The second set of tests were full-size tension members exposed to standard fire conditions in a furnace. This paper summarises a report by Barber (1994).

INTRODUCTION

Steel rods epoxied into glulam timber are a relatively new method of making high strength connections in timber structures. Typical examples are shown in figure 1.

This type of connection was developed in Denmark by Riberholt (1986).

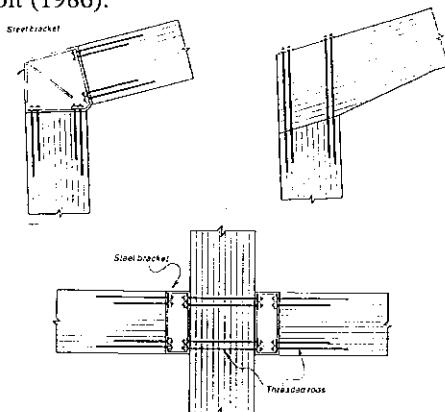

Figure 1 - Examples of epoxy rod connections (Buchanan & Fairweather, 1994)

Research in New Zealand conditions has been carried out by Townsend (1990), Buchanan and Fairweather (1993) and Deng (1994). Experimental work has been carried out using radiata pine. These connections have been used in a small number of major glulam structures (Buchanan and Fletcher, 1989; McIntosh 1989). The advantages of epoxy rod connections are hidden fasteners, fabrication off the building site, protection of steel from corrosion and fire resistance.

Connection Resistance to Load

The epoxied rod connection resists forces by transferring loads from the steel into the epoxy and then to the wood fibres. Epoxy to wood bond strength is due to a combination of adhesion and microscopic penetration of the epoxy into the wood. The main component of resistance between the threaded rod and the epoxy is mechanical bearing of the threads as shown in figure 2.

Smooth steel rods are not used because adhesive bond between the steel and epoxy cannot be relied on.

REFERENCES

- Cooney, R.C. Collins, M.J.; 1979 "A wall bracing test and evaluation procedure". BRANZ Technical paper P21. (Rev. 1987).
- King, A.B; Lim, K.Y.S: "Supplement to P21: An evaluation of P21 test results for use with NZS 3604:1990". BRANZ Report TR 90.
- Lyngcoln, K.J: 1987: "Wood based panels - Properties required for their use in the tropics with special reference to low cost housing". Expert consultation on wood based panels, FAO, Rome
- McLaughlan, J.M: "Properties of treated and untreated Pinus radiata plywood after 12 years' weathering". NZ Journal of Forestry Science 21(1):96-110 (1991)

- PAA 1992 "Structural plywood bracing". Design manual, PAA, Brisbane.
- Page; D.R: "Getting the best out of radiata pine weatherboards" NZ Journal of Timber Construction, 7(2) 1992
- Reed, M,E; Walls R.J. 1992: "Construction Plywood Wall bracing system" Appraisal Certificate No 224 BRANZ
- Standards Australia AS1604: Timber - Preservative treatment - sawn and round. SA Sydney
- Standards New Zealand: NZMP3640 1992: Specification of the minimum requirements of the New Zealand Timber Preservation Council Inc. Standards NZ, Wellington
- Standards New Zealand: NZS 3604 1990: Light timber frame buildings. Standards NZ, Wellington

FIRE RESISTANCE OF EPOXIED STEEL RODS IN GLULAM TIMBER

Andrew H. Buchanan

Associate Professor in Civil Engineering
University of Canterbury, Christchurch, New Zealand
and David J. Barber
Design Engineer
Connell Wagner, Wellington, New Zealand

SUMMARY

This research investigates the fire performance of epoxied rod connections in glue laminated timber. The epoxied rod connection has been assumed to have good fire resistance due to timber possessing low thermal conductivity. To investigate how full-size connections would react at elevated temperatures, computer modelling was used to analyse heat transfer through the charring wood and was validated by two series of tests. The first set of tests was to investigate the tension strength of the connection at elevated temperatures (40 to 90°C) by using an oven to heat the epoxied rod connection. The second set of tests were full-size tension members exposed to standard fire conditions in a furnace. This paper summarises a report by Barber (1994).

INTRODUCTION

Steel rods epoxied into glulam timber are a relatively new method of making high strength connections in timber structures. Typical examples are shown in figure 1.

This type of connection was developed in Denmark by Riberholt (1986).

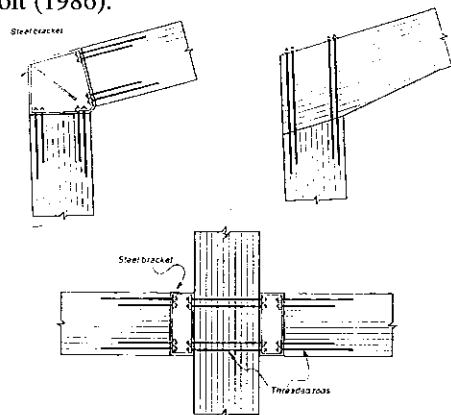

Figure 1 - Examples of epoxy rod connections (Buchanan & Fairweather, 1994)

Research in New Zealand conditions has been carried out by Townsend (1990), Buchanan and Fairweather (1993) and Deng (1994). Experimental work has been carried out using radiata pine. These connections have been used in a small number of major glulam structures (Buchanan and Fletcher, 1989; McIntosh 1989). The advantages of epoxy rod connections are hidden fasteners, fabrication off the building site, protection of steel from corrosion and fire resistance.

Connection Resistance to Load

The epoxied rod connection resists forces by transferring loads from the steel into the epoxy and then to the wood fibres. Epoxy to wood bond strength is due to a combination of adhesion and microscopic penetration of the epoxy into the wood. The main component of resistance between the threaded rod and the epoxy is mechanical bearing of the threads as shown in figure 2.

Smooth steel rods are not used because adhesive bond between the steel and epoxy cannot be relied on.

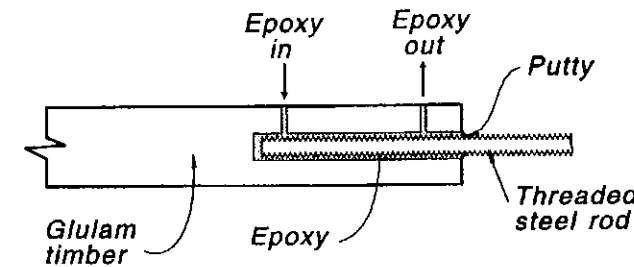

Figure 2 - Epoxied rod geometry

STRENGTH OF WOOD IN FIRE

Pyrolysis of Timber

Timber differs from most other common building materials because it is combustible. When heat is applied to wood a process of thermal degradation or pyrolysis occurs, leading to production of flammable vapours, accompanied by a loss of weight. Wood weight decreases initially above 100°C due to loss of moisture and at temperatures greater than 200°C complete carbonisation will start to occur. In the presence of oxygen the pyrolysis gas leaving the surface may be ignited and flaming combustion will be self-sustaining if enough of the heat is retained by the wood. A surface charcoal layer is then formed, which because of its low thermal conductivity (one third to one half of that of solid wood, Mikkola 1990) becomes good protection against heat for the interior timber. The charcoal layer also obstructs the oxygen access from the outside to the interior combustion zone.

Eventually flaming will stop unless there is sufficient external heat impinging on the surface. The penetration at the edges of the cross-section is also more rapid, giving a more rounded shape to the edges of the section. The penetration of heat into the pyrolysis zone can be increased by cracks or other deformities in the timber.

Strength of Wood

A simple approximation used in design of wood members, is to assume that the wood below the char layer is at ambient temperatures, with full strength properties. A more precise analysis must recognise that there is a temperature gradient through the pyrolysis zone and into the unburned wood. The strength of wood drops at elevated temperatures, as described by Schaffer (1997) and The Wood Handbook (1987).

ADHESIVES

A wide range of adhesives are used in wood construction, for glue laminating and epoxy bonding. Tests have shown that commonly available thermosetting adhesives used for manufacturing glulam have no adverse effect on embedment is longer. Deng has

Failure of the connection can occur in five ways, each of which can be affected by fire and elevated temperatures:

- failure by shear within the epoxy, along a plane at thread top height
- bond failure at the wood / epoxy surface
- wood failure in splitting, due to lack of confinement
- wood failure in tension
- yielding of steel bar in tension

derived an empirical pullout equation for tension parallel to grain for differing bar types and epoxies, giving predicted pull-out strengths of 139 kN for K80 and 117 kN for West System.

Construction of Test Connections

Holes were drilled in the wood with hand-held equipment and cleaned with compressed air. The threaded rods were cleaned by rag and wire brush. To ensure epoxy would completely cover the threaded rod and bond well with the wood, 3mm of epoxy was placed around the entire rod, by drilling a 26mm hole for each 20mm diameter bar.

The epoxy was mixed following the manufacturer's instructions, injected into the pilot hole until it began to flow out of the air-hole (see figure 2), and continuously topped up as it slowly filled all the voids between the steel and the wood and soaked into the wood.

A temperature sensor was glued into each test specimen, in the epoxy cavity with the wires extending out an air-hole.

Test Procedure

Each test specimen was placed in a pre-heated oven and left for 24 hours to obtain uniform temperatures.

The test samples were loaded into the testing machine directly from the nearby oven. The installation took about one minute to complete and the temperature drop was only 1-2°C by the time of failure. Each test specimen was loaded at a rate of 2cm/min, a faster rate than that used by Townsend (1990) and Deng (1994), to reduce the temperature drop. The specimens were loaded until timber failure or a large pull-out deflection occurred.

Test Results

The test results are summarised in figure 3 where it can be seen how the tension strength was reduced by elevated temperatures. There is scatter in the results, but the trend is obvious.

The scatter in the results is less as test temperature increases, showing the importance of the epoxy at higher temperatures where failures occur within the epoxy rather than within the wood.

The lines of figure 3 have been sketched by eye, arranged so that there are about the same number of data points on each side. The failures can be categorised in three stages,

- (i) Full strength, unaffected by heat (temperatures below approximately 45°C)
- (ii) Critical temperature reached, with resulting reduction in strength as temperature increases (temperature 45 to 70°C)
- (iii) Residual strength in the connection (temperatures 70 to 90°C).

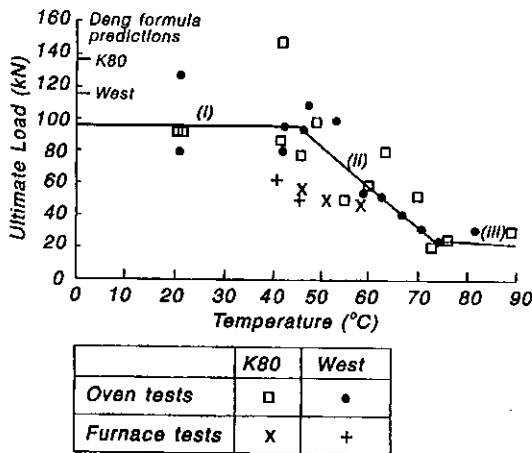

Figure 3 - Test results

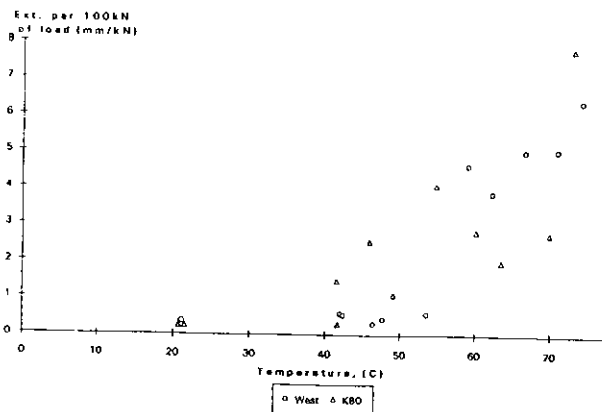

Figure 4 - Deformations at failure in oven tests

Figure 4 shows the measured deflection of the steel relative to the wood as the epoxy softens indicating that the West System epoxy reaches a critical temperature at approximately 55°C. The K80 epoxy is more variable with a critical temperature of 45-50°C.

Typical load deflection curves are shown in figure 5. Failures are much more ductile at elevated temperatures.

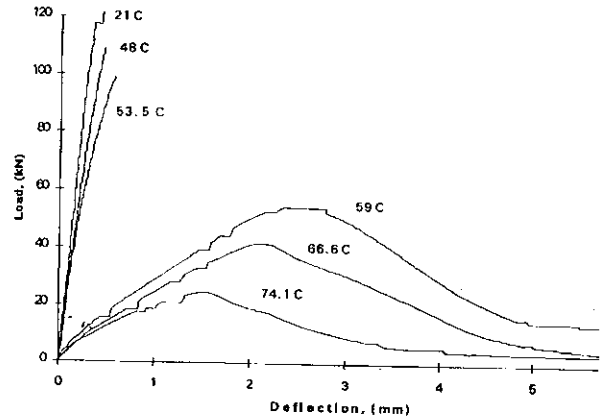

Figure 5 - Typical load deflection curves for West System epoxy

Failure Modes

The type of failures occurring are as follows,

- (a) Confinement failures are brittle failures with large splits extending down the test specimen (figure 6). Some failures were initiated by cracks occurring during drying.
- (b) Brittle tension failures in the wood, at the end of the steel bar, or remote from it are due to tensile strength of the wood only. Failure is induced by weaknesses in the timber as knots and the drilled holes (figure 7).
- (c) Shear failure in the epoxy due to the elevated temperatures is slow and ductile and either occurs with slight splitting around the connection as some confinement is lost, or simply by a pure shear failure in the epoxy at thread-top height.
- (d) Bond failure between the wood and epoxy, causes a plug of epoxy to withdraw from the connection hole with the bar intact. A bond failure was usually accompanied with some form of shear failure in the epoxy (figure 8).

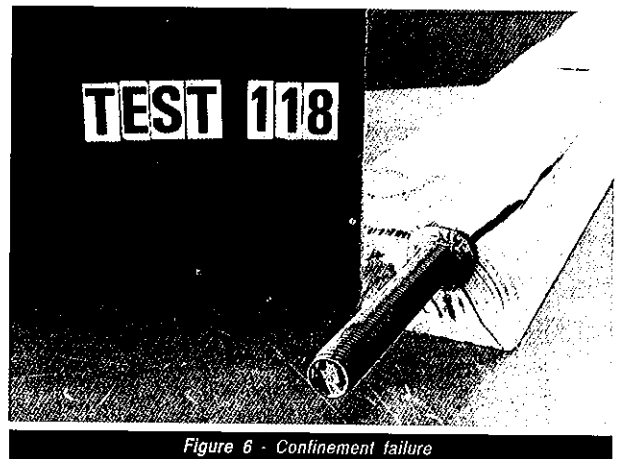

Figure 6 - Confinement failure

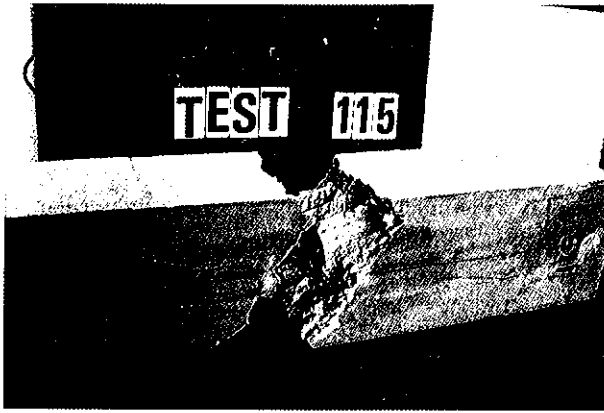

Figure 7 - Wood tension failure

and a load factor of 0.5 to allow for reduced load combinations under fire conditions, the calculated tension force is 50 kN.

Thus a tension load of 50 to 60 kN was applied during the test. Based on strength predictions, 50kN corresponds to 36% of K80's ultimate tension strength and 43% of West's ultimate tension strength.

These loads are severe, as most connections would normally have steel of yield strength 300 or 430MPa, resulting in loads of 22kN and 32kN respectively. Thus the steel rod is not highly loaded, but the wood and epoxy are. This is to ensure failure occurs within the wood-epoxy connection and not in the steel.

BTL Furnace

The BTL pilot furnace is diesel fuelled with internal dimensions of 2.2m long x 1.0m wide x 450mm deep. The three specimens were positioned across the 2.0 metre length at 500mm centres. The test specimens were loaded in tension using a reaction frame with a load-cell and a jack (figure 9).

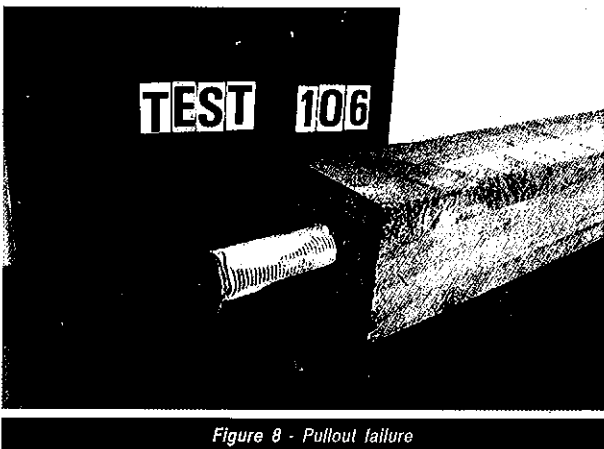

Figure 8 - Pullout failure

Failures a and b occurred at temperatures approximately less than 50°C, whilst failures c and d occurred at temperatures greater than 50°C, in both K80 and West test specimens.

FURNACE TESTS

Full scale furnace tests were conducted using the BTL (Building Technology Limited) pilot furnace at Judgeford, near Wellington. The furnace temperature followed the ISO834 Standard Fire.

Each epoxy was tested with three embedment lengths, 250mm, 300mm and 350mm. The completed test specimen had dimensions of 156 x 134 x 200 mm with a mid-span splice made using a 20mm diameter threaded rod. Thermocouples were glued to the threaded rods to measure the temperature of the epoxy inside the splice.

A fire-resistant caulking, Fyreflex, was applied on the ends of the timber members before they were butted together and glued in place.

Force Applied

The tension load was based on a stress level of 0.6 of yield strength (f_y) under code specified loads. For steel rods with $f_y = 680\text{MPa}$, a nominal diameter of 20mm,

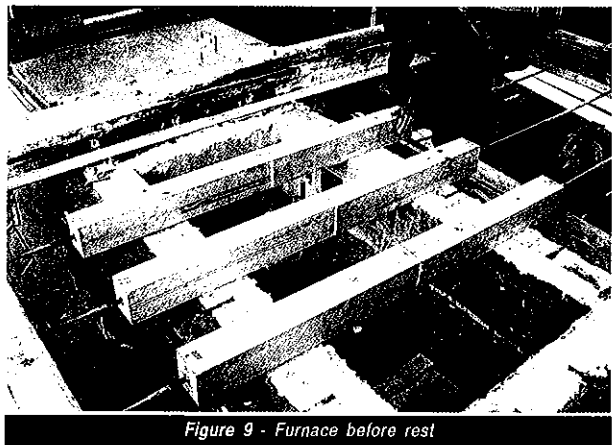

Figure 9 - Furnace before rest

The load was applied to each of the test splices using a hydraulic pump to apply the same pressure to each jack, resulting in similar loads. The pump was used to keep hydraulic pressure constant throughout the test. Stops were laced on the splice extension bars to limit movement to 30-40mm so that pressure in the hydraulic system would not be lost, even after one specimen had failed.

As the West specimens were being loaded before the test, the 300mm embedment length splice failed. The splice failed slowly at approximately 25kN.

On inspection it was found that the glue had only partially cured in the splice. The failure was disappointing as it left only two West system splices for comparison, but showed that even under laboratory conditions, problems can occur in the mixing of the epoxies.

OBSERVATIONS AND TEST RESULTS

Test 1, K80

Failures occurred at the following times, epoxy temperatures and loads:

- 250mm embedment length
-46 mins, 45.7°C, 56.6kN
- 300mm embedment length
-48 mins, 50.9°C, 50.0kN
- 350mm embedment length
-49 mins, 58.3°C, 46.7kN

All failures were slow, taking 2 to 3 seconds to move the allowable 40mm. Each timber specimen burnt timber evenly across its section leaving residual sections with dimensions of 55-65 x 70-80mm. Char removal was achieved by scraping of the charcoal until the brown heat affected wood was exposed. The rate of charring increased towards the centre of the splice due to the heat re-radiating from each of the splice ends, causing an elevated rate of burning (figure 10).

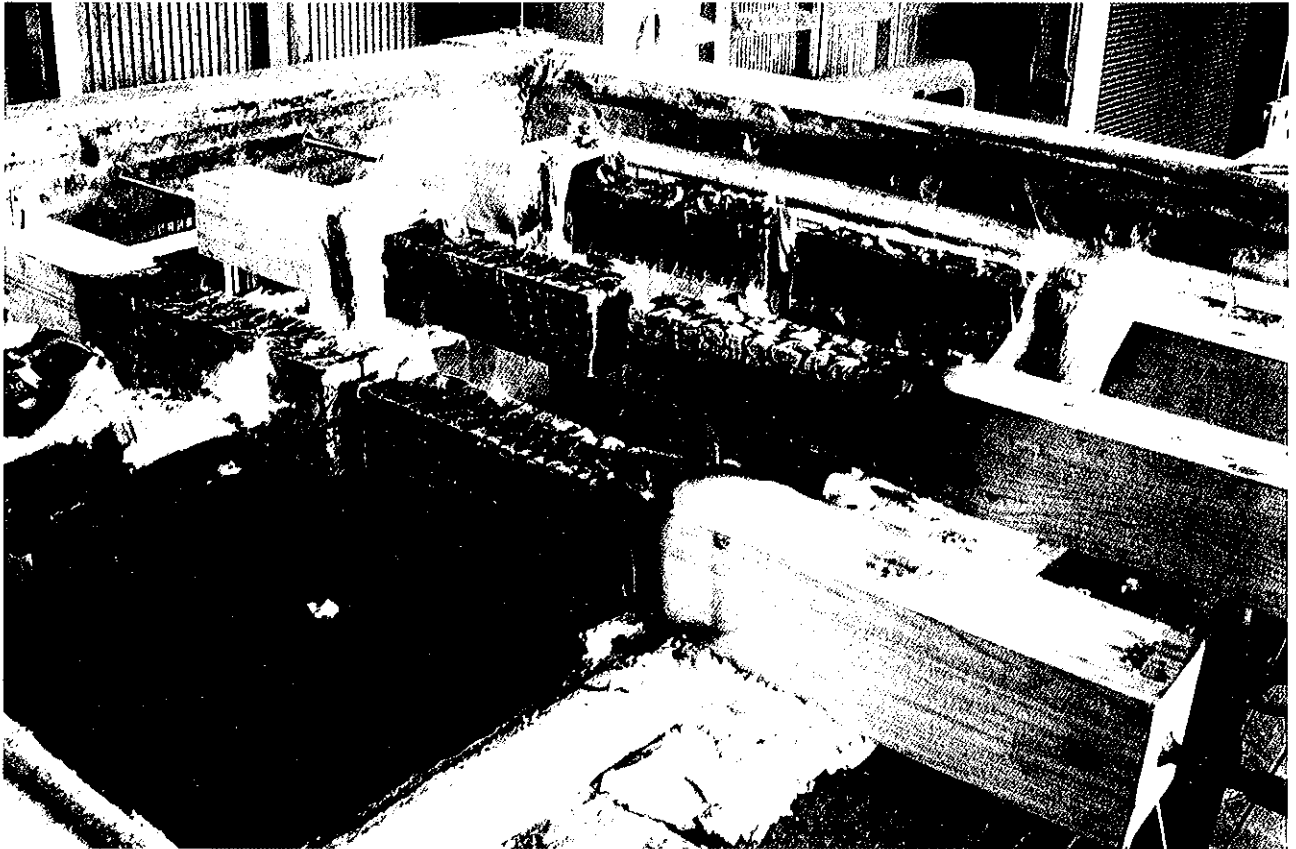

Figure 10 - Furnace after the test

Once the char was removed the stem of glue that had cured in the construction air-hole (see figure 2) was able to be seen. The K80 epoxy had charred at a lesser rate than the timber and was level with the outside edge of the char.

Test 2, West System

Failures occurred at the following times, epoxy temperatures and loads:

- 250mm embedment length
-42 mins, 40.2°C, 61.6kN
- 350mm embedment length
-44 mins, 45.1°C, 50.0kN

The 250mm embedment length specimen failed in a brittle manner due to a bond failure at the timber epoxy interface. Once the specimen was removed from the

furnace it could be seen that the epoxy was still completely bonded to the threaded bar and a small amount of wood up to 1mm thick, was attached to the outside of the epoxy in some places. The timber was split open on one side suggesting a typical confinement failure, but with the epoxy remaining intact around the bar.

The 350mm embedment length specimen failed by a slow shear failure in the epoxy with the splice moving the limiting 35mm in 2-3 seconds. The shear failure occurred by both shattering of the epoxy and movement along a shear plane at thread-top level. This failure mode was observed often in the oven tests.

Once char had been removed from the timber the residual sections were of the size 60-65 x 75-85mm.

The charring rate was again faster towards the centre of the splice. As the char was removed around the air-holes it was evident that the West glue had charred faster than the timber.

Load At Failure

Due to the rapid sequence of failures in each of the furnace tests, it was not possible to remeasure the load cells once one specimen had failed. As all three specimens were attached to the same reaction frame it is likely that once one failed, the load would have increased on the remaining specimen(s). This increase in load could have been enough to induce premature failure within the surviving specimens at an unknown load level considerably higher than the initial load.

Charring Rate

The rate the wood charred at during burning in the furnace could easily be measured once the specimens were cut through their cross-section. The boundary between charred and uncharred timber is distinguishable from the heat-affected timber that is dark brown. Measurements of the uncharred wood were taken at the

boundary between charred and heat-affected wood. Charring rates measured were 0.68mm/min parallel to the laminations and 0.69mm/min perpendicular to the laminations.

Comparison With Oven Tension Tests

When the furnace data for load and temperature is plotted with the data from the oven tension tests, the general trend is followed (see figure 3). The furnace data shows failure at lower loads than was occurring for the oven tests, for the same temperature. However, the loads may have been significantly greater than those plotted for the second and third failure in each test.

TASEF MODELLING

In an attempt to understand the process of heat transfer into the epoxied connection during fire exposure temperatures were predicted using TASEF which is a finite element heat transfer programme (Sterner and Wickstron 1990) developed specifically for fire engineering applications. The finite element mesh is shown in figure 11.

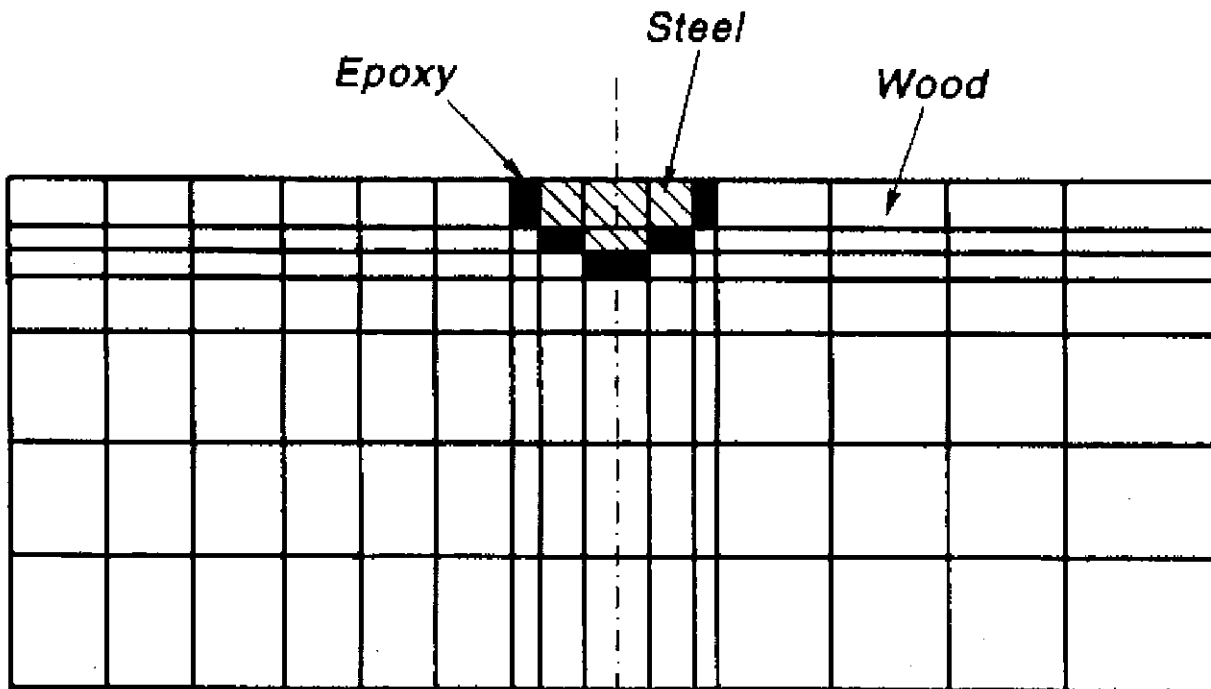

Figure 11 - Finite element mesh

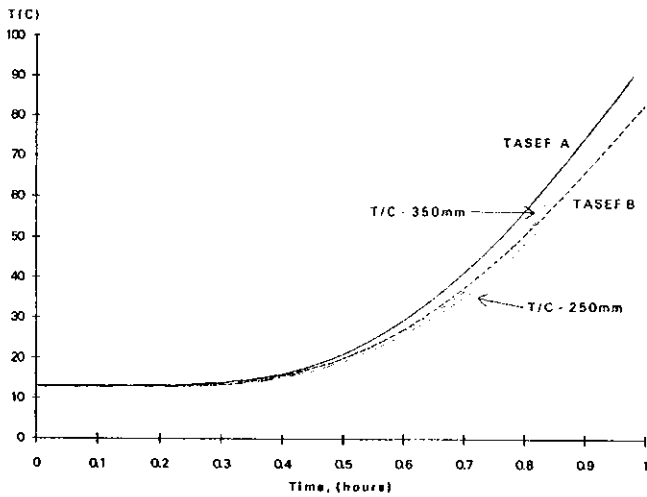

Figure 12 - Comparison of measured and calculated temperatures

Typical results are shown in figure 12, where the temperatures in the furnace test are seen to be accurately predicted.

DESIGN

The oven tests and the furnace tests have demonstrated that epoxied connections will perform satisfactorily as long as the epoxy remains below a critical temperature of about 50°C.

The TASEF programme has been used to predict the time for the epoxy to reach 50°C for a range of beam geometries, (figure 13). It can be seen that when exposed to the standard test fire the critical temperature of 50°C is reached at between 15 and 35 minutes depending on beam geometry.

A similar analysis was performed using the time temperature curves expected in real fires. The time to reach critical temperature was found to not differ much from the ISO 834 standard fire.

CONCLUSIONS

Both the West System and Nuplex K80 epoxies reach a critical temperature at approximately 50°C (West at 55°C and K80 at 45°C). Strength decreases rapidly once this temperature is reached.

Elevated temperature failure is by pull out due to shear failure within the epoxy or loss of bond.

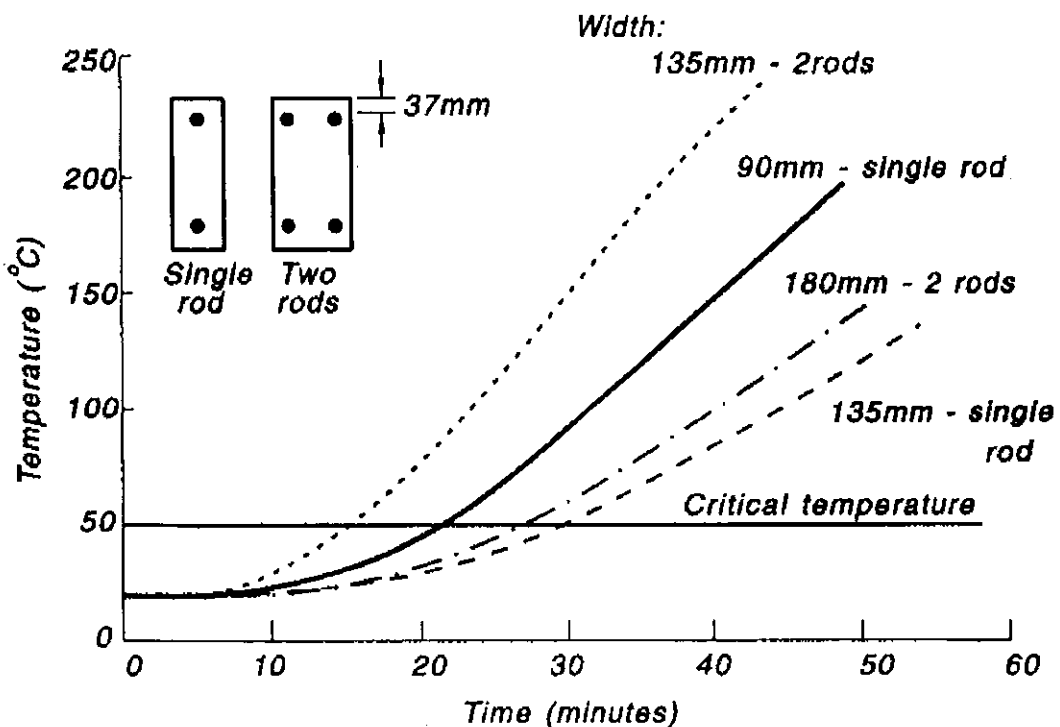

Figure 13 - Predicted temperatures in beams