

# RAIN SCREEN TECHNOLOGY

Dr. G B Walford, NZ Forest Research Institute Ltd

## THE PROBLEM

The system of exterior cladding for timber frame buildings that uses stucco is being used very widely in New Zealand – sometimes with disastrous results. Likewise with stucco or sprayed-on textured coating over polystyrene foam – called “chillybin” construction. In the Northwest United States and in Western Canada similar construction has led to losses running to billions of dollars. That part of the world has high rainfall, like much of New Zealand. The problem lies not with the materials so much as with the system. What has happened is that water has penetrated the exterior cladding and has been unable to drain away, or to evaporate. Untreated timber in contact with moisture and warmth is bound to decay and it will do unnoticed, provided the interior lining does not collapse first. Boric treated timber will stand occasional but not continuous wetting. Typical construction uses building wrap over the timber frame and fibre-cement sheet, followed by stucco. The use of reinforced plastic TYVEK building wrap is an improvement over building paper but not the complete answer because it is inevitably punctured by nails and staples. BRANZ (2001) has also just published an article on this, pointing out that “there has been little research done as yet in New Zealand.....the following is the best advice we can give at the present”.

## THE SOLUTION

It did not take much thinking to work out what was wrong, and to come up with a solution. This is described by Hazleden and Morris (1999). The solution relies on good design and can best be expressed as “Rain Screen Technology” or “The 4 D’s”. These four lines of defence are illustrated in Figure 1 and are listed in order of importance.

- **Deflection** means the use of wide eaves to deflect rain off the walls. This is fine for a single storey building but wide eaves are not a popular architectural fashion. Besides, there are still the gable ends of a house to contend with. Nevertheless deflection is the first line of defence and this is estimated to be capable of dealing with perhaps 90% of rain incidence on a building. I see the draft Standard for earth housing requires eaves to half the wall height. That does limit its design but the thinking is the same.
- **Drainage** means that there is a cavity between the exterior cladding and the building paper or wrap. It also means that there are adequate flashings. Some disasters have occurred where builders thought that modern spray-on exterior thick film coatings did not need flashings but that is another story. Hazleden and Morris (1999) say “There is considerable discussion as to whether drainage is possible between stucco and the building paper, using one or two layers of paper. Due to doubts as to the effectiveness of this system, the City of Vancouver has mandated a 19 mm cavity using battens behind stucco.” Here stucco means reinforced plaster rendering possibly with fibre-cement sheet support.
- **Drying** means that there is an air flow through the cavity and no opportunity for water to be trapped or ponded. A gap to allow air flow through the cavity behind the exterior cladding is essential. At the top of the wall some kind of overhang or flashing is needed to cover the gap. At the bottom care needs to be taken to ensure that the gap remains open and that creeping plants or vermin do not enter.
- **Durability** means that if water gets to the timber it will not decay. Untreated timber will tolerate occasional wetting provided it dries quickly. How quickly is a matter of some debate, but it is generally thought that if the moisture content stays above 25%, decay fungi may become established in as little as three months. The battens creating the cavity behind the exterior cladding must be H3 treated because moisture will wick into the crevice between the batten and the building paper. With a drainage cavity the studs are unlikely to need treatment but as a fourth line of defence or insurance, H1 treatment can be specified. Boron salts (H1) are a very effective fungicide

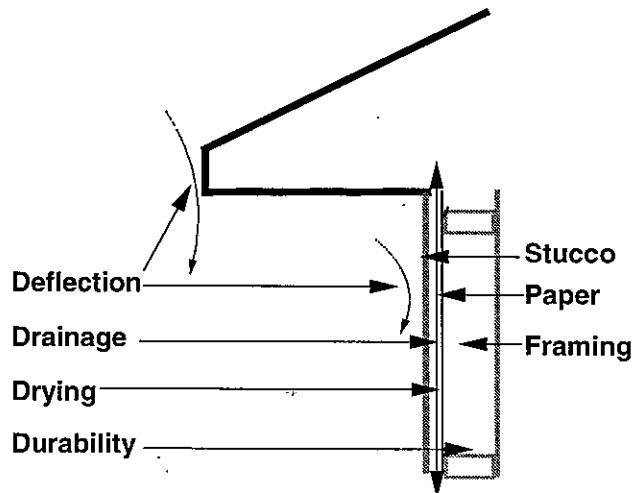

Figure 1. Illustration of the 4 Ds

and do not leach out unless there is running water on the timber. H3 treatment would be overkill for framing but necessary for the battens.

Figure 2 shows the exterior cladding arrangement used on multistorey apartment buildings in Vancouver, BC, Canada.

1. Plywood Sheathing
2. Building wrap - 2 layers
3. Battens
4. Separation board
5. Flashing
6. Gap
7. Gap above flashing
8. Vinyl siding
9. Ventilation gap

Apart from the use of vinyl siding, this detail is notable for the cavity created behind the siding, and the drainage/ventilation created at each floor level. Make a few changes and you have the answer for the New Zealand situation:

- Replace the plywood sheathing with fibre-cement sheet or use Gib Braceline® for the interior lining.
- Use treated timber battens over the building wrap along the line of each stud.
- Replace the vinyl siding with stucco or whatever.

## PROS AND CONS

What are the fish hooks in this solution?

The ventilation gaps create a haven for spiders. A fine mesh at the bottom should stop that.

The painted timber separation board at each floor level would require painting so omit that. Just make sure that there is a continuous line of flashing and an air gap at each floor level to ventilate the cavity. It may be that a line of flashing and a gap is not required at each floor level. If that was omitted then the appearance would be exactly the same as is being achieved now. The ventilation gap at the top and the bottom of the wall would not be visible.

Another consideration might be fire. Although small, the ventilation gap could act as a chimney and carry fire between apartments. A separation with appropriate flashing is necessary at each floor to ensure fire separation.

## REFERENCE

D G Hazleden, PI Morris, 1999; Designing for durable wood construction: The 4 Ds. 8<sup>th</sup> International conference on durability of building materials and components, Vancouver, Canada.

Tony Condor, 2001; Drained and ventilated cavities for wall claddings. Build, July/August

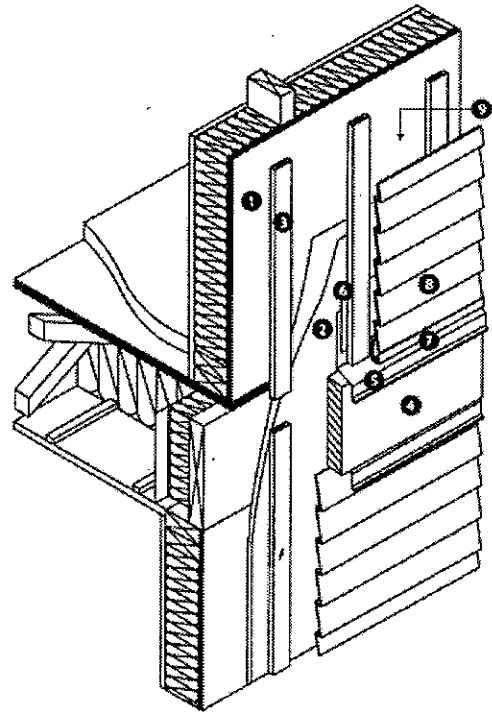

Figure 2. Vancouver example